

Technical Specifications Triple Green Products

Flue Gas Cyclone

Made in North America



Flue Gas Cyclone Model		DC-154	DC-277	DC-345	DC-500	DC-563	DC-662	DC-750	DC-993	DC-1157	DC-1323	DC-1654	DC-1985	DC-2315	DC-2645	DC-3075		
Dimensions (in.)	A Width	36	36	36	48	48	48	48	65	65	65	78	78	78	91	91		
	B Length	96	96	96	96	96	96	96	144	144	144	144	144	144	144	144	144	
	C Height	122	122	122	122	122	122	122	141	141	141	151	151	151	151	151	151	
	D Overall	170	170	170	170	170	170	170	198	198	198	221	221	221	221	229	229	
	E Height	123	123	123	123	123	123	123	130	130	130	153	153	153	153	153	153	
	F Overall	60	60	60	60	60	60	69	69	69	69	69	69	69	69	69	69	69
	G Overall	46	46	46	46	46	46	55	55	55	55	55	55	55	55	55	55	
Flue Gas Fan	Motor HP	5	5	7.5	7.5	10	10	10	10	15	15	20	20	25	25	30		
DC Air-Lock	Motor HP	0.5	0.5	0.5	0.5	0.5	0.5	0.5	0.5	0.5	0.5	0.5	0.5	0.5	0.5	0.5		
Cyclones Per System	Unit	6	6	10	12	12	12	12	24	24	24	30	30	30	36	36		
Chimney Size	(in.)	10	10	12	12	14	16	16	16	16	18	18	20	20	22	24		
Mass Flow	ACFM	310	348	520	900	1159	1272	1725	1912	2143	2607	3012	3475	4229	5213	6082		
Weight Approximate	LBS	2,500	2,500	2,500	3,600	3,600	3,600	3,600	4,200	4,200	4,200	4,800	4,800	4,800	5,800	6,200		

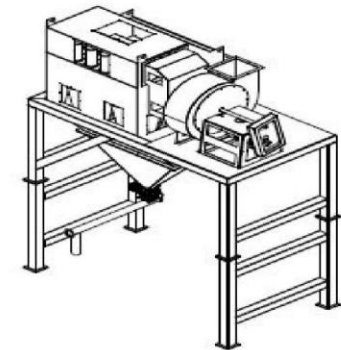
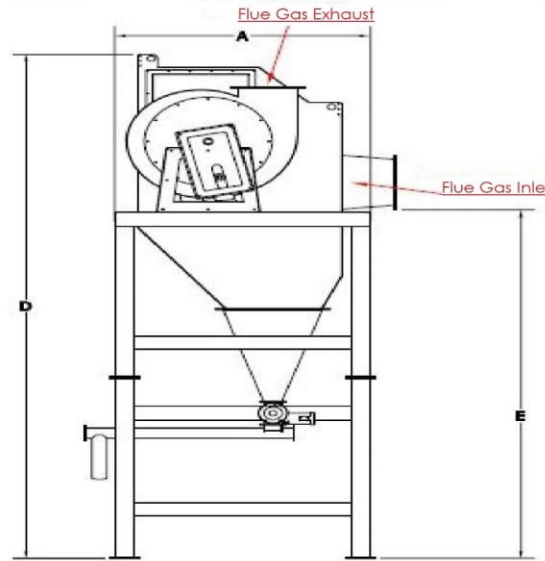
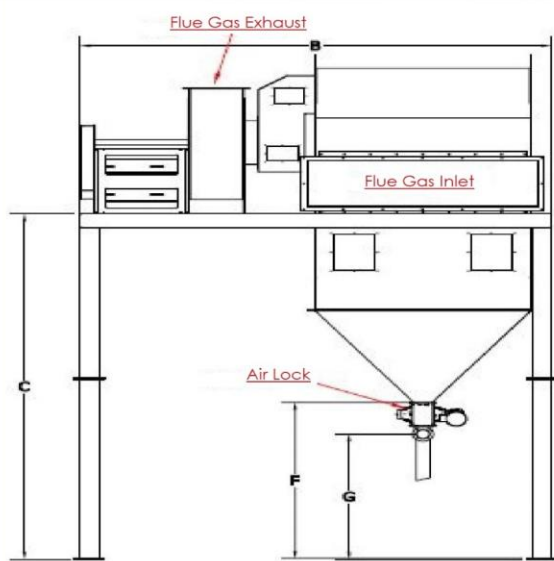

Emission test results available upon request.